

COMBUSTIBLE GAS DETECTOR

The Combustible Gas Detector with MCU technology and the advanced low-current gas sensitivity components, enables detecting the gas leaked in time, then send out the alarm signal correctly. The Detector accords with the standard of "Household Gas Detector" of GB15322-2003.

GENERAL VIEW

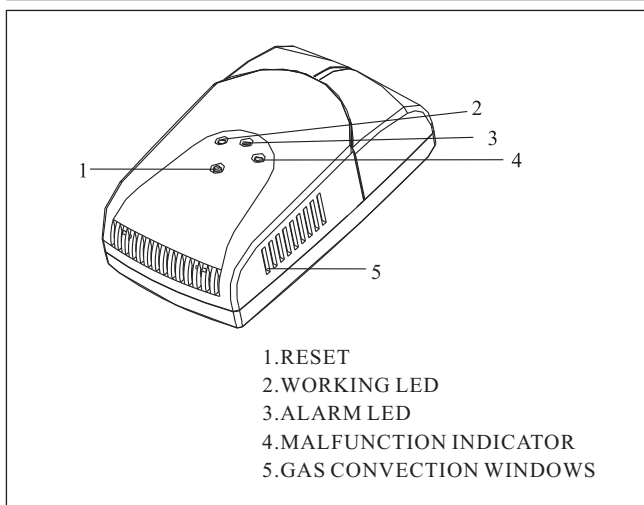

TECHNICAL SPECIFICATIONS

Induced gas	Natural gas
Power input	DC12V/AC220V50Hz
Static current	<70mA
Working current	<140mA
Alarm Density	10%LEL
Buzzer level	≥70dB at 1m
Operating temperature	-10℃~+50℃; humidity: ≤90%RH
Stableness	≤±5%LEL
Repetition	≤±5%LEL
Alarm Density Error	≤±5%LEL
Alarm Mode	Flash & sound alarm/Network alarm signal
Size	120*70*44mm

NOTE: calibrating gas is CH₄

TERMINAL BLOCK FIGURE

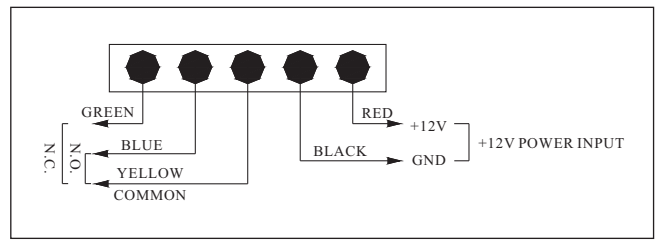

INSTALLATION

1. Choosing a suitable position to install the Detector, normally at 0.3-1.0m below the ceiling, the best distance to the gas source is no more than 1.5m.

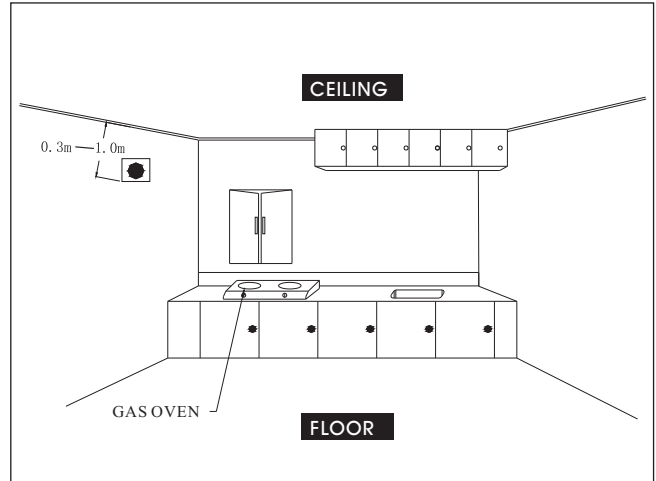

2. Fix the mounting board on the suitable position by screws, then mount the detector on the board and check if it is firm or not.

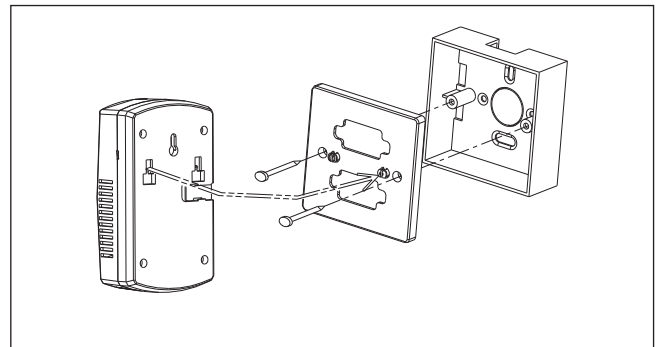

3. Avoid installing the detector close to the following sources of interference: direct air flow from vents, fans, doors, windows, sources of steam, oil vapor, etc.

WIRES INSTALLATION DIRECTIONS

All wiring installation must be consistent with valid rule and standard. The size of core must be suitable. The wire connecting alarm to other accessories should have colorful identifier for avoiding wrong connection. The irrelevant connection will result in wrong alarm.

USAGE

The Household Gas Detector can be used as a kind of alarm independently, or with network, valve controller linkage, exhaust fan function optional.

1. Independently:

- (1) Choosing the suitable position to install the Detector according to the INSTALLATION.
- (2) With DC 12V or AC 220V power supply, The circuit enters auto-test state, red/green/orange LED flashes one second at the same time, the buzzer sounds “ Di ” and then it enters warm-up state. The green LED lights, that means the Detector enters normal working state.

2. In Network

- (1) Installing the Detector according to the INSTALLATION, choose N.C. or N.O. contact optional accord with the controller system.
 - (2) With DC 12V or AC 220V power supply, the circuit enters auto-test state, red/green/orange LED flashes one second at the same time, the buzzer sounds “ Di ” and then it enters warm-up state. The green LED lights ,that means the Detector enters normal working state.
- 3.While detected the gas leaking, the red LED flashes, the Buzzer sends out the alarm sound Di Di , and the network output signal. The Detector will resume for the detecting state after the gas taken off.
4. Orange LED lights, that means the inner malfunction.
5. After there appears inside malfunction, push the RESET and the alarm will enter auto-test state. If the orange LED lights again, please contact sale-after service department .

TEST

To test the installed Detector while using independently or in network, you can give some gas around in distance of 5cm to the gas convection windows by using un-ignition lighter. Gas testing frequently may result in reducing the sensitivity of the Detector. The alarm density of gas is set according with the criteria of CJ3057-1996.The Detector will stop alarm and resume the detecting state while the gas density reduced. The alarm output switches can connect with the defense input switches of alarm system.

NORMAL MAINTENANCE

Suggestion: the user must brush and clean the gas convection windows with a little cleanser every three months, and must retest the Detector after cleaning for preventing the cleanser into the Detector.

EMERGENCY ALARM TREATMENT

The Detector alarms while the gas density in air beyond the alarm density. The relative treatments as below:

1. Shut down the tube valve right away.
2. Open the window and make the air flow rapidly.
3. Extinguish all fire sources and anything can make fire, e.g. lighters, matches, etc.
4. Avoiding open/close all kinds of electricity.
5. Check the reason of gas leaking, and notice the relative departments and professional persons in time.

LED INFORMATION

Ren led flash	gas leak
Green led flash	running the inside sensor
Green led on	working normally
Orange led on	Inside malfunction

NOTICE

1. The detector must be installed and connected accordingly. It can not work if without the power supply orderly.
2. Please periodically maintenance according to the directions.
3. The Detector must have a test every half a year.
4. For various reasons, including, but not limited to, changes in environmental conditions, electric or electronic disruptions and tampering, the Product may not perform as expected. The user is advised to take all necessary precautions for his/her safety and the protection of his/her property.