

Installation Instructions for the DS308EA Microprocessor-Based Quad PIR Detector

1.0 Specifications

- **Input Power:** 6.0 to 15.0 VDC; 25 mA @ 12.0 VDC.
- **Standby Power:** There is no internal standby battery. Connect unit to DC power sources capable of supplying standby power if primary power fails. For each hour of standby time needed, 25 mAh are required. *For UL Certificated installations, four hours of standby power (100 mAh) are required.*

- **Coverage:**
 - Broad (standard):** 15.3 m by 15.3 m (50 ft. x 50 ft.)
 - Barrier (optional):** 24.4 m by 5 m (80 ft. x 20 ft.)
 - Long Range (optional):** 36.6 m by 3.1 m (120 ft. x 10 ft.)
- **Sensitivity:** Standard or Intermediate.
- **Alarm Relay:** Form "C" (NC/C/NO) reed relay with contacts rated at 28 VDC, 125 mA maximum for DC resistive loads.
- **Tamper Switch:** Normally Closed (with cover in place) tamper switch. Contacts rated at 28 VDC, 125 mA maximum.
- **Trouble Output:** Normally Closed contact opens when the detector is in a trouble condition. The contact is rated for 125 mA @ 28 VDC.
- **Anti-Mask:** Anti-Mask detection circuitry with Spray Detect option detects attempts to sabotage the detector and provides a trouble output.
- **Temperature:** The storage and operating range is -29°C to +49°C (-20°F to +120°F). *For UL Certificated installations, the temperature range is +32° to +120°F (0° to +49°C).*
- **Options:** B328 Gimbal Mount Bracket, B335 Low Profile Mount Bracket, B338 Ceiling Mount Bracket, TC6000 Test Cord, OMB77-3* Barrier Mirror, and OMLR77-3* Long Range Mirror. **Shipped in packages of three.*

NOTE: Misalignment of the detector when using an optional mounting bracket may reduce the range.

- **Pointability:** The mirror is adjustable from +1° to -18° vertically and ±10° horizontally.
- **Patents:** This device is covered by one or more of the following U.S. patents: #4,764,755 and #5,083,106.
- **Compliance:** This device complies with Part 15 of the FCC Rules and with RSS-210 of Industry and Science Canada. Operation is subject to the following two conditions: (1) this device may not cause harmful interference, and (2) this device must accept any interference received, including interference that may cause undesirable operation.

Changes or modifications not expressly approved by Detection Systems, Inc. can void the user's authority to operate the equipment.

2.0 Mounting

2.1 Mounting Considerations

- Select a location that is most likely to intercept an intruder moving across the coverage pattern. The recommended mounting height range is 2 m to 2.6 m (6.5 ft. to 8.5 ft.).



Avoid mounting the detector in locations (such as above a doorway) where people may pass in close proximity (0.5 m/1.5 ft.) to the detector.

- The mounting surface should be solid and vibration free.
- Avoid direct hot and/or cold drafts, direct sunlight, heat sources, windows, air conditioning outlets, and small animals.
- This detector **won't** detect through glass.

2.2 Surface or Corner Mounting

NOTE: For bracket mounting, refer to the installations supplied with the bracket.

NOTE: The detector may also be mounted to a Single Gang Box. Use the bracket mounting hole as the wire entrance.

- Remove the cover. Insert a thin flathead screwdriver into the notch at the bottom of the cover and pry up.
- Loosen the chassis screw (see Figure A). This holds the circuit board/mirror unit (chassis) securely in place in case of rough handling (dropping).

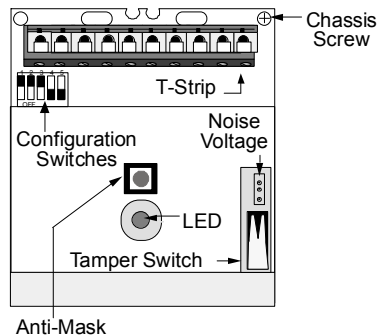

Figure A - Circuit Board

- Remove the circuit board/mirror unit (chassis) from the enclosure.
- Push the board/mirror unit toward the top of the enclosure until it clears its four retainer tabs, then lift out.
- Open two holes (see Figure B) for surface or corner mounting.

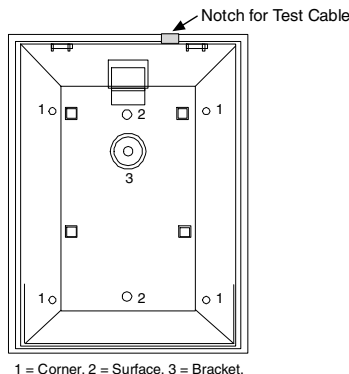

Figure B - Detector Enclosure

- Mark the location for the mounting screws. Use the enclosure as a template. Pre-start the mounting screws.



- Open the knock-out wire entrance and route the wiring through (see section 3.0).
- Securely attach the detector.
- Replace the circuit board/mirror unit.
- Select the Vertical Angle

Mirror Information: The mirror is adjustable +1 to -18° vertically and ±10° horizontally. To change the mirror, just pull it out from its resting grooves.

NOTE: Excessive handling of the mirror surfaces may lead to performance degradation.

The following chart (Figure C) will help you set the correct Vertical Angle based on the mounting height, mirror type, and desired range. If desired, the mirror may be adjusted ±10° horizontally as well by rotating (aiming) the mirror from side to side.

Mounting Height	Broad		Barrier		Long Range	
	9 (30)	15 (50)	15 (50)	25 (80)	25 (80)	36 (120)
2 (6.5)	-8°	-5°	-3°	-2°	-2°	-1°
2.3 (7.5)	-9°	-6°	-5°	-3°	-3°	-2°
2.6 (8.5)	-10°	-7°	-6°	-4°	-4°	-2°

Height and desired Range listed in meters (feet)

Figure C - Mounting Height/Range Chart

The angle adjust markings are on the sides of the mirror (see Figure D).

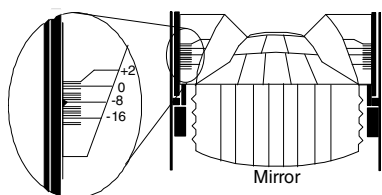

Figure D - Setting Vertical Angle

Slide the mirror forward or back until the angle hash marks are in-line with the markers on each side of the frame.

3.0 Wiring



Only apply power after all connections have been made and inspected.

Connect wiring as shown in Figure E.

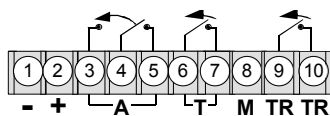

Figure E - Terminal Connections

Seal the wire entrance with the foam plug provided.

3.1 Terminal Descriptions

- **1 (-) & 2 (+):** Input Power. Use no smaller than 0.80 mm (#22 AWG) wire pair.
- **3 (NO), 4 (C), 5 (NC):** Relay Contacts. Reed relay for silent operation. Contacts rated at 3 W, 125 mA, 28 VDC maximum for DC resistive loads and protected by a 4.7 W resistor in the common "C" leg of the relay. Do not use with capacitive or inductive loads.
- **6 & 7:** Tamper Contact. Normally Closed, rated 28 VDC, 125 mA.
- **8:** Memory Input. Connect the (+) or (-) input for memory control. (See Section 8.1).
- **9 & 10:** Trouble. Normally Closed (NC) trouble contact. Rated for 125 mA @ 28 VDC.

4.0 Configuration Switches

Configure the detector using the appropriate switch settings (see Figure F).

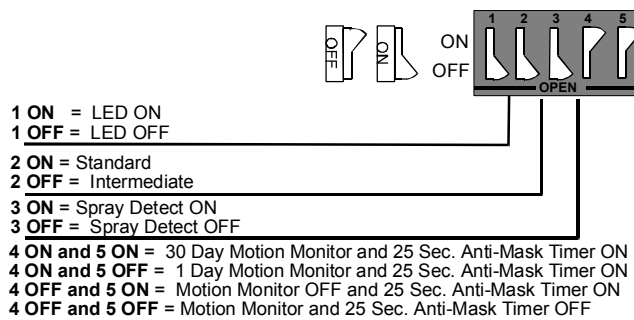

Figure F - Configuration Switch Locations

4.1 LED Operation (S1)

- **ON:** Allows the LED to operate when activated by alarm.
- **OFF:** The LED will not operate on alarm.

4.2 Sensitivity Mode (S2)

- **Standard Sensitivity:** Recommended setting for maximum false alarm immunity. Tolerates environment extremes on this setting. Not recommended for Long Range or Barrier type patterns. **The detector is shipped in Standard Sensitivity mode.**
- **Intermediate Sensitivity:** Recommended setting for any location where an intruder is expected to cover only a small portion of the protected area. Tolerates normal environments on this setting.

NOTE: Although the sensitivity modes provide different degrees of tolerance to environmentally caused alarms, the installer should assure peak background noise voltage readings do not exceed ±0.15 VDC from reference levels. (See Figure F and Section 6.0).

4.3 Spray Detect (S3)

- When enabled (S3 ON) the detector will give a trouble output if the detector lens has been coated with a foreign substance.

4.4 Motion Monitor/Anti-Mask Timer (S4 and S5)

- Set for the desired Motion Monitor time and for Anti-Mask Timer (see Figure F and Section 7.0 for Motion Monitor and Section 8.2 for additional information). **The detector is shipped with the Motion Monitor and 25-second Anti-Mask timer features disabled.**

5.0 Setup and Walk Testing

NOTE: The walk test may also be activated by switching the Memory control voltage. (See Section 8.1).

- Replace the cover on the unit. The cover should be in place before testing the unit.
- Apply power to the unit. The LED will flash until the detector is ready for testing.
- Wait for the LED to stop flashing (approximately two minutes if no motion is detected in the coverage pattern), then start walk testing.
 - Walk test **across** the coverage pattern as shown:
- The edge of the coverage is determined by activation of the LED.
- Walk test the unit from both directions to determine the boundaries.
- If the desired range **cannot** be achieved, try angling the mirror up or down to assure the coverage pattern is not aimed too high or low.

- Walk test the unit from both directions to determine the boundaries.
- If the desired range **cannot** be achieved, try angling the mirror up or down to assure the coverage pattern is not aimed too high or low.

6.0 Final Tests

NOTE: It is recommended that both channels be tested, one at a time, when performing final tests.

- Connect a DC VOM to the Noise Voltage pins (use of the TC6000 is recommended).
- Set meter scale for about 3.0 VDC.
- The base reference level for reading background noise is approximately 2.5 VDC.
- Installations in quiet environments will result in a steady reading between 2.4 and 2.6 VDC.
- Voltage changes greater than 0.75 VDC from the reference level are desirable for good catch performance.
- If changes are less than 0.75 VDC, the device may fail to respond if the temperature between the intruder and the background is minimal.
- Turn on all heating and cooling sources that would normally be in operation during times of protection.
- Stand away from the unit and outside the coverage pattern, then monitor the background noise for at least three minutes.
- Readings should not deviate from the reference level by more than ± 0.15 VDC.
- For readings outside these limits; eliminate the cause, re-point the unit slightly, or mask off the affected zones.

7.0 Supervision Features

A supervision trouble condition is indicated at the detector by the LED. The LED indicates the cause of the trouble using coded pulses. The trouble signal activates the trouble relay on terminals 9 and 10, which may be connected to a 24-hour zone.

The supervision features function as follows:

- **PIR:** PIR operation is checked electronically approximately every twelve hours. If the circuit fails, the LED will pulse four times and the Trouble output will activate.
- **Motion Monitor Supervision:** This feature verifies that the detector has a clear view of the detection area.
 - When selected, a supervision timer is activated. A trouble condition will be indicated if the detector has not alarmed at least once during the selected time period (this feature can be disabled by placing both switches [S4 and S5] in the OFF position or by placing switch S4 OFF and S5 ON if the Anti-Mask Timer is desired). The time period selected should be long enough to allow adequate time for holiday weekends.
 - If the time period selected has elapsed from the last alarm, the LED will flash two times and the Trouble output will activate.
 - If Memory (see section 8.1) is being used, the Motion Monitor timer will stop while the control is placed in the Armed (night) mode. The timer will resume when the control is subsequently placed in the disarmed (day) mode.
- **Trouble Reset:** An alarm activation will reset a motion monitor trouble condition and an Anti-Mask trouble condition. These trouble conditions may also be reset by temporarily removing power.

The following chart displays the LED response to the supervision features

LED	CAUSE
ON	Unit Alarm
2 Flashes	Motion Monitor Timeout
3 Flashes	Anti-Masking
4 Flashes	PIR Self Test Failure (detector needs replacement)

8.0 Other Features

8.1 Memory, Day Mode, Night Mode and Walk Test

NOTE: Memory, Night Mode and Walk Test require a supply voltage on Terminal 8 to activate these features (see Figure G for switching specifics). This supply voltage must be between 6 and 18 VDC. You may use a switch as shown below:

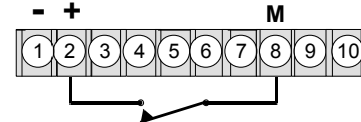

Or use an external power supply as shown below:

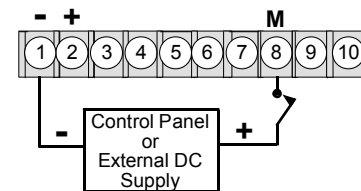

NOTE: Control voltage: +6 to +18 VDC = ON (Switch Closed)
0 VDC = OFF (Switch Open)

- **Day Mode:** The Day Mode disables the alarm memory and allows the LED (if activated) to operate normally.
- **Memory:** When the DS308EA is in the Night Mode the memory is activated. This allows the detector to store an alarm for display at a later time.
- **Night Mode:** The Night Mode enables the alarm memory and disables the LED operation.
- **Walk Test:** When the DS308EA is in the Walk Test mode, the LED will indicate the current alarm status regardless of the setting of the LED ON/OFF switch (Switch 1).

Desired Action	Control Voltage (Terminal M)
Turn ON Night Mode/ Reset Stored Alarm	ON (for more than 20 seconds)
Turn Off Night Mode/ Display Stored Alarm	OFF
Turn On Walk Test (if OFF)	ON (for more than 5 seconds but less than 20 seconds)
Turn Off Walk Test (if On)	ON (for more than 1 second but less than 20 seconds)

Figure G - Mode Switching

8.2 Anti-Masking/Spray Detection

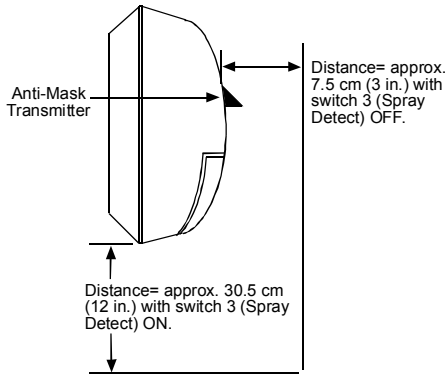

Figure H - Antimasking Coverage

The Anti-Masking/Spray Detection option prevents accidental or intentional blocking of the detector by detecting an object placed in close proximity of the detector or if the detector is sprayed with a foreign substance.

NOTE: The Anti-Mask function is always enabled. If you wish to disable the Anti-Mask function, cover the Anti-Mask Transmitter (See Figure A) with masking tape.

NOTE: It takes approximately 25 seconds for the detector to react to a masked or sprayed condition if the Anti-Mask Timer is enabled (see section 4.3).

If the Anti-Masking circuitry activates, it will cause a supervision trouble condition, the Alarm/Test LED will flash three times and the trouble relay will activate.

The Anti-Masking circuitry may interpret removing and replacing of the cover as an attempt to mask the detector. After a 10 second quiet period, the trouble condition will automatically reset upon the next alarm activation. Also, momentarily removing power from the detector will reset the trouble condition.

9.0 Maintenance

- At least once a year, the range and coverage should be checked in accordance with the Walk Testing section.
- To ensure proper daily operation, the end user should be instructed to walk through the outer edge of the coverage pattern daily. This assures an alarm output prior to arming.

10.0 Coverage Patterns

This product is factory assembled with the look down zones (O, P, and Q) masked out. If you wish to use these zones, simply remove the masking tape from the lens.

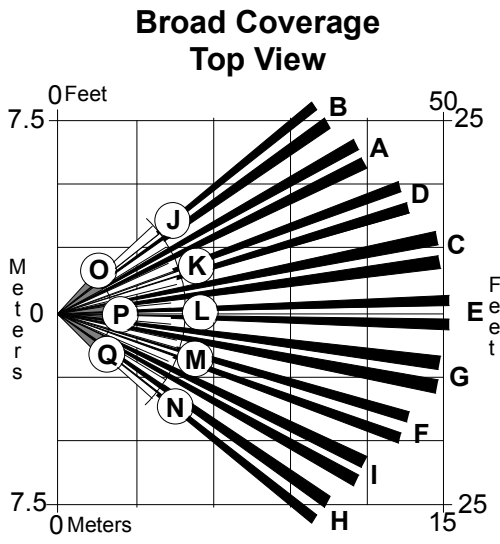

Side View

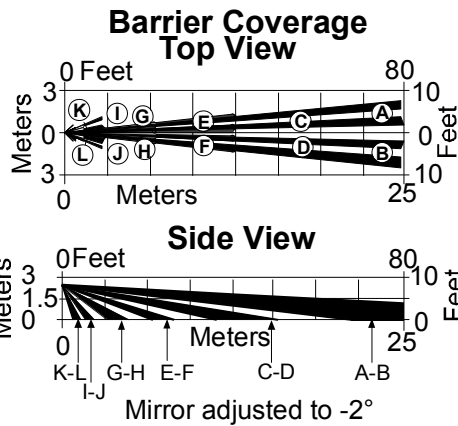
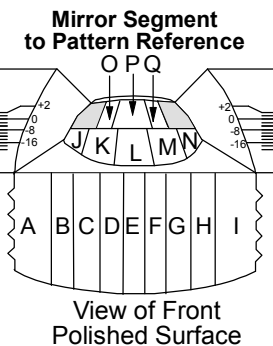
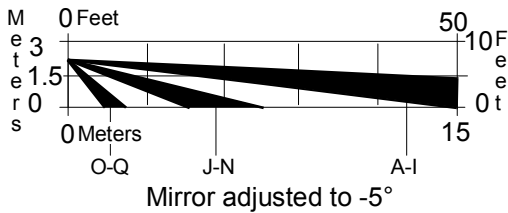

Side View

Mirror adjusted to -2°

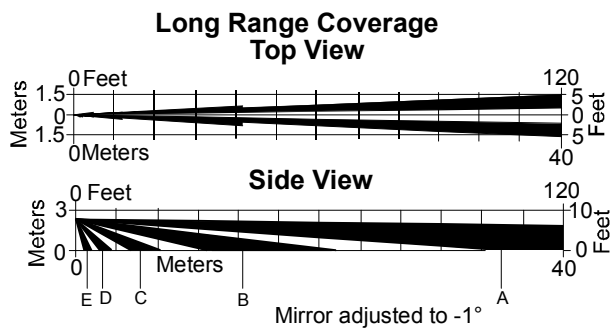
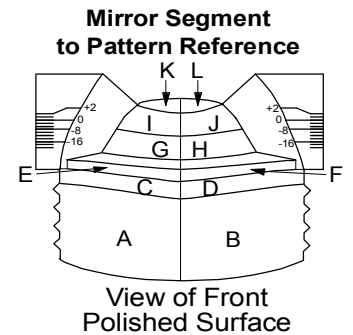

Side View

Mirror adjusted to -1°

